

# Temposonics®

Magnetostrictive, Absolute, Non-contact  
Linear-Position Sensors



## C-Series Core Sensor Models CS and CM Analog or SSI Outputs

Document Part Number  
551020 Revision L

### Data Sheet



Core sensor  
Models CS/CM

Core Sensor with  
H2 housing

Core sensor Model with  
M Style Housing

#### FEATURES

- Non-Contact - No Wear - Such as Found With Pot Wipers On Conductive Mylar, Particularly When Mounted On Dithered Actuators or Vibrating Installations
- Stroke Length 72 mm (2.83 in.) to 250 mm (9.84 in.)
- Low Power Needs - Allows Use With Printed Circuit-Level Supplies of +5 Vdc or +12 Vdc
- No Drift - No Periodic Re-Calibration Needed
- Optional Housings - Allows Exposed Use by Offering Mounting Options And Several Levels of Environmental Protection
- Optional Magnet Choices Allow Greater Range of Installation Configurations
- Customizable Active Zones - Offers Full Output Sensitivity for Smaller Active Zones
- Customizable Reading Direction - Forward or Reverse Acting Analog Output Allows Match to Control Requirements

◇ Contact factory for more information

#### BENEFITS

- Embeddable Core Sensor Design Allows OEMs To Reduce The Cost of Sensor Installation By Providing Appropriate Sensor Environmental Protection via Their Product Design.
- When Embedding The Sensor is Not Viable, Two Optional Environmental Housings Allow The Core Sensor to Be Used In a Variety of Service Environments, Including High Pressure and Liquid Level.
- Light Weight - Ideal For Small or Portable OEM Products
- Low Cost - Total Cost Competitive With Linear Pots or LVDT's - Initial Cost + Warranty + Cost of Goodwill.
- Small Size - This Is The Smallest Package In The Market That Has all The Benefits Of Magnetostrictive Sensing and Fits Where No Other Magnetostrictive Sensor Can

#### APPLICATIONS

- OEM Products That Require An Embedded, Tightly Integrated Sensor Solution
- Externally Mounted Continuous Position or Liquid-Level Measurement

#### MARKETS

- Medical Treatment Equipment and Mobility Devices
- Entertainment Automation
- Marine Steering and Trim
- HVAC
- Food Preparation and Exercise Equipment
- Off-Road Equipment
- Suspension
- Any High-Volume Markets That Require Low-Cost, Embeddable Position Sensing

#### Product overview

The Core Sensor is a complete, functional sensor in every respect making it ideal for embedded sensor applications where the OEM product provides all the environmental protection necessary for the application and any additional sensor protective housing would be redundant, representing unnecessary cost in extremely cost sensitive moderate to high volume OEM products.

There are two C-Series Core sensor models, CS and CM. Model CS is available in a analog voltage and is used for general applications offering a 5 volt supply and has a ratiometric output. The model CM analog voltage sensor is available in two version and is intended for mobile equipment applications that operates off 12 volts, has an internal reference voltage that makes the output independent of power supply fluctuations, and offers extended EMI performance and extended over voltage protection.

The model CM sensor is also available with SSI serial digital output that runs off 5 or 12 volts and has a 24 bit, 5 volt high output. C-Series Core Sensors are also available with accessory housings that afford environmental protection and mounting options when embedding is not appropriate for the application. They are factory assembled with the sensor ready to use. These housings can be used in high pressure applications such as cylinders, immersed with a float for liquid level measurement, and as a means to add sensors as an aftermarket upgrade.

All specifications are subject to change. Contact MTS for specifications and engineering drawings that are critical to your application. Drawings contained in this document are for reference only. Go to <http://www.mtssensors.com> for the latest support documentation and related media.

## C-Series Core Sensor, Models CS/CM

### Product Specifications

#### Product specifications

Parameters	Specifications
<b>OUTPUTS</b>	
<b>Measured output variables:</b>	Linear position, single magnet
<b>Resolution:</b>	<b>Analog:</b> Infinite (limited by ripple on the power supply) <b>Digital:</b> 100 $\mu$ m standard, 50 $\mu$ m possible on custom basis
<b>Update rate:</b>	<b>Analog:</b> 500 Hz (2 ms period) <b>Digital:</b> 1500 Hz (0.6 ms period)
<b>Linearity deviation:</b>	$\pm$ 0.3 mm full stroke , $\pm$ 0.15 mm without correction using a 401842 magnet between null +10 mm and full scale -10 mm
<b>Repeatability:</b>	$\pm$ 25 $\mu$ m
<b>Hysteresis:</b>	$\pm$ 25 $\mu$ m
<b>Analog outputs:</b>	<b>CS:</b> 2% to 98% of 5 Vdc supply, ratiometric with supply <b>CM:</b> 0.1 Vdc to 4.9 Vdc at 12 Vdc supply (not ratiometric with supply)
<b>Digital outputs:</b>	Synchronous Serial Interface (SSI) (RS-422 type differential signal pairs) <b>Data format:</b> Binary standard (gray code optional), optional parity bit <b>Data length:</b> 24 bit <b>Data speed (Baud rate):</b> 100 kBd to 400 kBd, depending on cable length (see below)
<b>Length m:</b>	< 50    <100    <200    <400 m
<b>Baud rate:</b>	<400 kBd   <300 kBd   <200 kBd   <100 kBd
<b>Zero setpoint tolerance:</b>	<b>Core Sensors and Core Sensors in H and M-style housings:</b> $\pm$ 1 mm
<b>Stroke lengths in mm:</b>	<b>Core Sensors:</b> 73.3, 109.5, 148.0, 162.3, 186.3, 194.3, 217.3 and 250.1 <b>Core Sensors in H and M housings:</b> 72.3, 109.5, 148.0, 162.3, 186.3, 194.3, 217.3 and 250.1

Parameters	Specifications
<b>ELECTRONICS</b>	
<b>Operating Voltage:</b>	<b>CS Analog:</b> 5 Vdc, - 5%, + 10 % <b>CM Analog:</b> 12 Vdc, $\pm$ 25 % <b>CM SSI:</b> 12 Vdc, - 15%, +20%
<b>Supply current:</b>	<b>Analog:</b> 40 mA typical <b>SSI:</b> 80 mA typical
<b>Over voltage protection:</b>	<b>CS Analog:</b> Up to 20 Vdc <b>CM Analog:</b> Up to 30 Vdc <b>CM SSI:</b> Up to 30 Vdc
<b>Output short to ground:</b>	<b>CS Analog:</b> Protected <b>CM Analog:</b> Protected <b>CM SSI:</b> Protected
<b>Polarity protection:</b>	<b>CS:</b> Vdc to Gnd <b>CM:</b> Vdc to Gnd <b>CM SSI:</b> Vdc to Gnd
<b>Output load:</b>	<b>CS/CM analog:</b> 10 k $\Omega$ <b>CM SSI:</b> Min. 100 $\Omega$ termination
<b>ENVIRONMENTAL</b>	
<b>Operating conditions:</b>	<b>Operating temperature:</b> -40 °C (-40 °F) to +75°C (+167 °F), higher temperatures possible, contact MTS. <b>Relative humidity:</b> 90%, no condensation with housing <b>Temperature coefficient:</b> <b>CS:</b> Voltage $\leq$ 20 microns/°C <b>CM:</b> Voltage $\leq$ 20 microns/°C <b>CM SSI:</b> $\leq$ 20 microns/°C
<b>EMI:</b>	<b>CM:</b> Contact factory <b>CS:</b> Contact factory
<b>Shock rating:</b>	5 g (single hit)
<b>Vibration rating:</b>	1 g, 10-150 Hz/ IEC standard 68-2-6

<b>WIRING</b>	
<b>Connection types:</b>	<b>P1 Core Sensors:</b> JST PHR-4 (Analog) or JST PHR-6 (SSI) socket female (24 AWG) crimp pin, JST 04KR-6 or JST 06KR-6 (26 AWG) insulation displacement (pigtailed available on custom basis) <b>H-style housing:</b> pigtail cable, 3 (analog) or 6 (SSI) conductors, 24 AWG, 1 meter long <b>M-style housing:</b> M12 5-pin (analog) or 8-pin (SSI) connector

**Product specifications**

Parameters	Specifications
<b>MECHANICAL PACKAGING</b>	
<b>CORE SENSORS</b>	
<b>Electronic head:</b>	Glass filled plastic
<b>Sealing:</b>	IP50/IP40
<b>Sensor tube:</b>	Nylon, sealed tip
<b>Mounting:</b>	User determined, provisions for two M3 screws, 37 mm or longer (knock out of plastic seal barriers required)
<b>Magnet types:</b>	401842 ring, 400424 ring, 252012 ring, 253572 ring, 201611 float, 201656 float
<b>Hazardous substance compliance:</b>	2002/95/EG RoHS
<b>H STYLE HOUSING</b>	
<b>Electronic head:</b>	Stamped 316L (1.4404) stainless steel cover and flange
<b>Sealing:</b>	IP67 o-ring seals inside on core head - two places, gasket for flange
<b>Sensor tube:</b>	304L (1.4306) stainless steel pipe and plug
<b>Mounting:</b>	Two bolts or screws, 180°, X holes.
<b>Magnet types:</b>	401842 ring, 400424 ring, 252012 ring, 253572 ring, 201611 float, 201656 float
<b>M HOUSING</b>	
<b>Electronic head:</b>	Machined 303 (1.4305) stainless steel Hex body and cover
<b>Sealing:</b>	IP69K (when connected to mating cable)
<b>Operating pressure:</b>	250 bar (3600 psi), 325 bar max (4700 psi)
<b>Sensor tube:</b>	304L (1.4306) stainless steel, 316 (1.4404) plug, laser welded
<b>Mounting:</b>	M14 x 1.5 threads with 11.3 x 2.2 mm NBR o-ring
<b>Typical mounting torque:</b>	45 Nm (33 foot-pounds)
<b>Magnet types:</b>	Standard ring magnet part no.: 401842 Optional ring magnet part no.: 254012 Optional ring magnet part no.: 400424 Large ring magnet part no.: 253572 Std. magnet float part no.: 201611 Std. slim magnet float part no.: 201656

**C-Series Core Sensor, Models CS/CM**  
**Mounting, Wiring and Connections, Accessory Options**

**Sensor outputs**

C-Series Core sensors are available in standard analog and SSI (Synchronous Serial Interface) outputs. Analog output is  $\pm \approx 0$  to 5 Vdc in both CS and CM models. In the CS, the output is ratiometric with the supply voltage. In the CM, the 12 volt supply allows the sensor to generate a reference 5 volts for the circuit so the output is not ratiometric with the supply voltage.

**Synchronous Serial Interface (SSI)**

Temposonics C-Series model CM core sensors with SSI output offer clocked serial data transfer. The displacement value is encoded in a 24-bit binary or gray code format and transmitted at high speed via SSI interface in RS-422 or RS-485 standard to the control device. The synchronous serial interface is the most widely used output between sensors and controllers.

A clock pulse train from a controller is used to gate out sensor data. One bit of position data is transmitted to the controller for each clock pulse received by the sensor (see 'Figures 1 and 2'). The absolute position data is continually updated by the sensor and converted by the shift register into serial information.

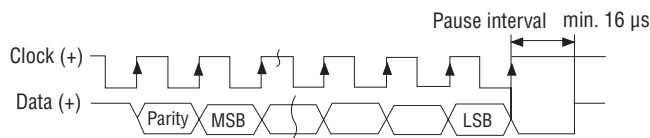

**Figure 1.** Timing diagram

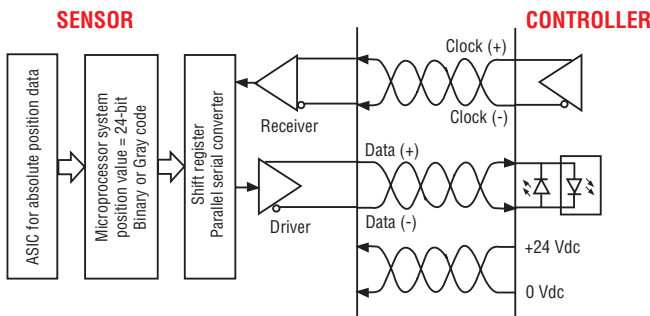

**Figure 2.** Logic diagram

The first high-low transition of the clock load the actual position information and the parity bit into the output register. The first low-high transition transmits the parity bit to the data output. The second low high transition transmits the MSB of the actual position information to the data output. At each subsequent low-high transition the next highest bit is transmitted to the data output. When the least significant bit is received by the controller the pulse train is terminated. After a pause interval, the data output returns to logic 1.

Between each clock pulse train there is a minimum dwell of 25  $\mu$ s during which fresh data is moved into the register. Data is shifted out when the sensor receives a pulse train from the controller. When the least significant bit (LSB) goes high and the minimum dwell time has elapsed, new data is available to read.

**Parity Bit explanation:**

Bit 25 is the parity bit. The parity bit is set to no parity (always 0) as standard and even parity on request. Even parity means for the data output it contains an even number of bits which contain a logic 1 (high level), including the parity bit (see 'Figure 1')

**Example:**

If the 24 bit number is 2345 decimal then this is 100100101001 binary. By counting the number of 1s we yield 5. The parity bit will be set to a 1 because of the even parity.

**Error detection**

With the parity bit and the intelligent sensor electronic sufficient error detection should be possible. The detection will cover the following failure modes:

Error detected	Possible cause
Parity bit doesn't match	Data signal is corrupted
All data bits are logic 0	No magnet detected
All data bits are logic 0	Data output shorted to ground or open
Parity bit doesn't match. All data bits are high	Data output shorted to power supply

Input and output are standard RS-422/RS485 differential signal levels.

Contact MTS applications engineering for synchronous operation as an option for timing critical applications.

## Models CS/CM Sensor Dimension References

the C-Series core sensor is available in two models, CS and CM and are intended for embedded applications in OEM products. The C-Series model CS is designed for general purpose applications and requires a 5 Vdc power supply. The C-Series model CM is designed specifically for mobile equipment applications and provides additional protection from over voltage and reverse connection and supports a 12 Vdc power supply. The C-Series core sensor can be ordered with a housing option for applications that require additional protection. Due to the plastic housing, core sensors require consideration of protection from external magnetic fields when installed in OEM products.

### MODEL CS/CM CORE SENSOR

**Notes:**

1. Stroke lengths are calculated from the side of the magnet facing the sensor's head.
2. Dimensions for models CS and CM are the same. Both models have plastic breakaway seals that must be removed from the mounting holes (shown in 'Figure 3') before use.

*Drawing is for reference only, contact applications engineering for tolerance specific information.*

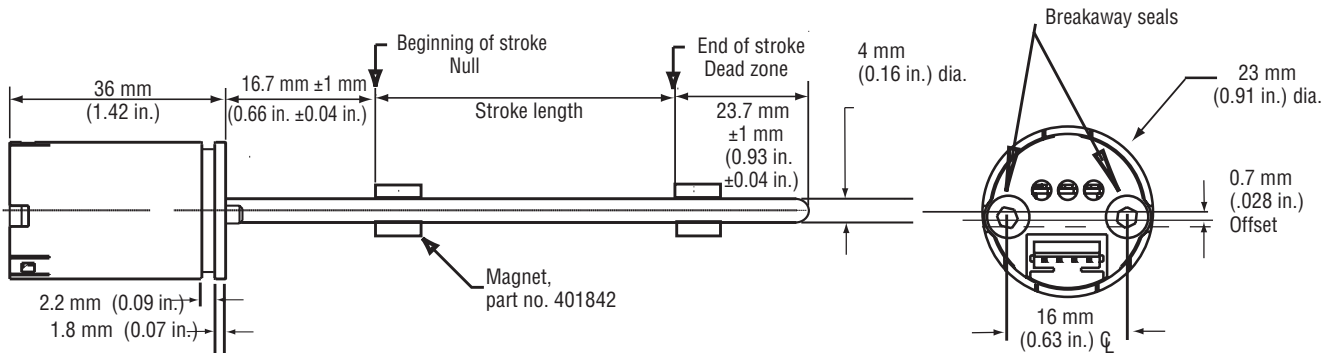
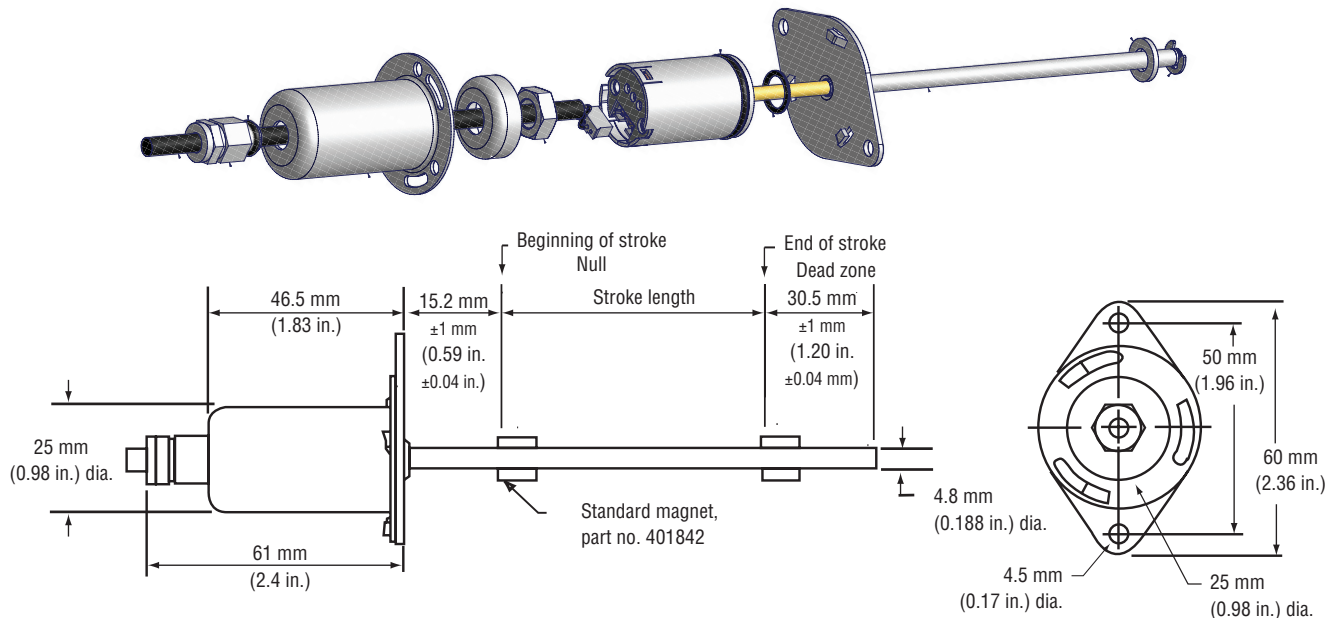

**Figure 3.** C-Series Core sensor, Models CS/CM dimension references

### MODEL CS/CM CORE SENSOR WITH IP67 H2 HOUSING OPTION

*Drawing is for reference only, contact applications engineering for tolerance specific information.*

The H2 housing option completely encloses and seals the C-Series sensor to IP67 ratings. It's made of 304L stainless steel and is available with a cable out only. The cover is locked in place with tabs. However, the cover can be removed by bending the tabs outward. O-rings seal the outside environment on the inside diameter and on the C-Series null zone face. This H2 housing is easy to mount via the two holes on the flange. Two gasket types are available to seal the flange upon installation. The pressure rating of the flange to the tip of the sensor is 300 psi (24 Bar). This sensor can be used with magnets or magnet equipped floats. A retaining clip groove is located in the end of the pipe to secure the available floats from falling off during installation or low fluid conditions in liquid level applications.



**Figure 4.** C-Series Core sensor, Models CS/CM (with IP67 H2 housing option) dimension references

**C-Series Core Sensor, Models CS/CM**  
**Sensor Dimension References**

**Dimension references, model CS/CM sensors with R and M-style housing options**

**MODEL CS/CM CORE SENSOR WITH IP69K M-STYLE HOUSING OPTION**

*Drawing is for reference only, contact applications engineering for tolerance specific information.*

The M-style housing option completely encloses and seals the C-Series sensor to a IP69K rating. A Hex flange and M14 x 1.5 threads provide easy mounting through tapped holes. The sensor is available with a connector (M1 housing option) or a cable (M2 housing option). Pressure rating is 5000 psi (350 Bar), suitable for high pressure hydraulic or pneumatic environments. Floats can be used with this sensor, but the float center hole must be large enough to accommodate the pipe diameter. A groove is supplied for E-clip float retention. The rod is 304 stainless and the hex is 316 stainless.

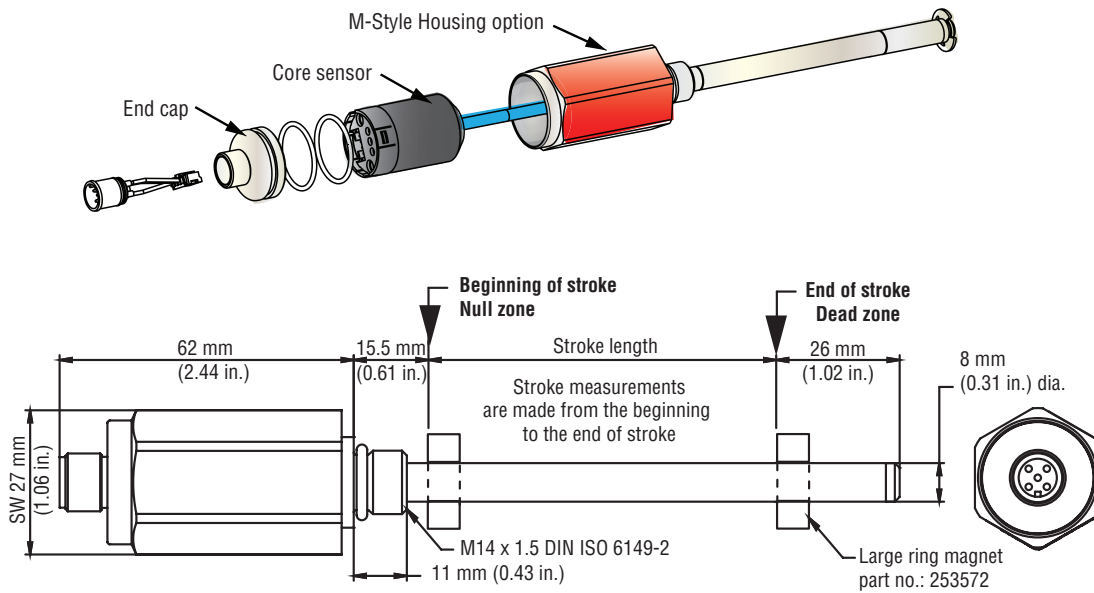
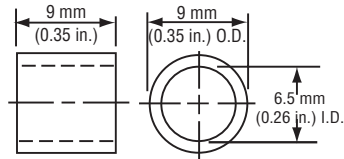

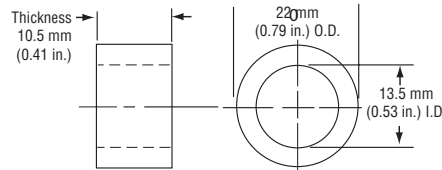

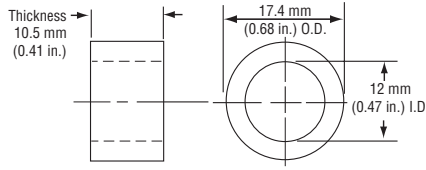

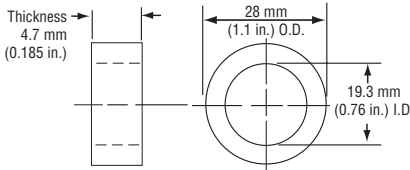

**Figure 5.** C-Series Core sensor, Models CS/CM (with IP69K M-Style housing option) dimension references



**Magnet and connector selections**

Magnets must be ordered separately for core sensor models CS/CM and sensor models with M or H housing options. The magnet is included when ordering the R-style housing option.





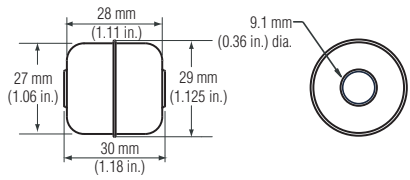

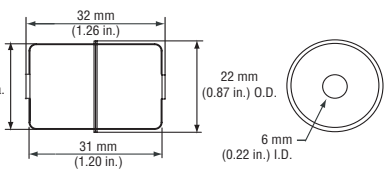
**Magnets (must be ordered separately, one required per sensor)** *(Drawing dimensions are for reference only)*

Magnet and magnet dimension reference	Sensor model/function	Description	Part number
 	<b>CS/CM</b> Standard magnet	<b>Standard ring magnet</b> O.D.: 9 mm (0.35 in.) I.D.: 6.5 mm (0.26 in.) Thickness: 9 mm (0.35 in.)	401842
 	<b>CS/CM</b> Optional magnet	<b>Optional ring magnet</b> O.D.: 22 mm (0.79 in.) I.D.: 13.5 mm (0.53 in.) Thickness: 10.5 mm (0.41 in.)	254012
 	<b>CS/CM with M-style housing</b> Standard large multipole magnet	<b>Large ring magnet</b> O.D.: 17.4 mm (0.68 in.) I.D.: 12.0 mm (0.47 in.) Thickness: 10.5 mm (0.41 in.)	253572
 	<b>CS/CM</b> Optional magnet For applications that require a magnet to provide increased clearance.	<b>Optional ring magnet</b> O.D.: 27.94 mm (1.10 in.) I.D.: 19.25 mm (0.758 in.) Thickness: 4.7 mm (0.185 in.)	400424

**Float Options (must be ordered separately, one required per sensor)** *(Drawing dimensions are for reference only)*

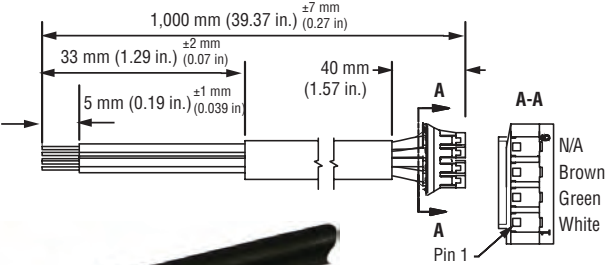
Float and float dimension reference	Function	Description	Part number
 	<b>CS/CM with H2 and M-style housings</b> Standard wide float with magnet.	<b>Standard wide float</b> O.D.: 29 mm (1.3 in.) I.D.: 9 mm (0.36 in.) Depth: 30 mm (1.18 in.) Specific gravity: 0.83 g/cm <sup>3</sup> Max. Material: 316L stainless steel	201611
 	<b>CS/CM with H2-style housing</b> Standard slim float with magnet	<b>Standard slim float</b> O.D.: 22 mm (0.87 in.) I.D.: 6 mm (0.22 in.) Depth: 32 mm (1.2 in.) Specific gravity: 0.67 g/cm <sup>3</sup> max. Material: 316L stainless steel	201656

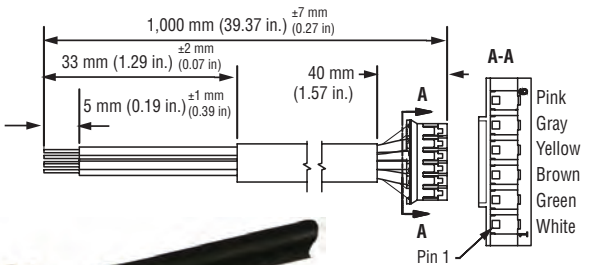
**C-Series Core Sensor, Models CS/CM**  
**Connector Selections**

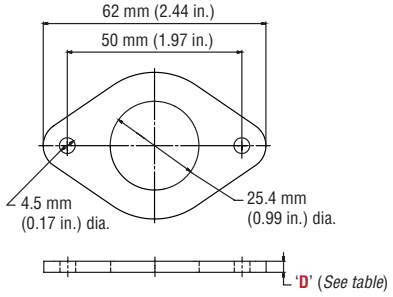
<b>Mating Connector and Cable Assembly Options</b> <i>(Drawing dimensions are for reference only)</i>												
<b>Connector reference</b>	<b>Function</b>	<b>Description</b>	<b>Part number</b>									
	<b>CS/CM (Analog output)</b> Insulation displacement mating connector for 26 AWG wire	<b>JST KRD 4-pin connector (04KR-D6S-P)</b>	370500									
 	<b>CS/CM (Analog output)</b> Mating connector with 1 meter, 24 AWG cable	<b>Cable assembly, crimp style JST PHR-4 connector with 1 meter cable</b>	253396									
	<b>CS (SSI output)</b> Insulation displacement mating connector for 26 AWG wire	<b>JST KRD 6-pin connector (06KR-D6S-P)</b>	370536									
 	<b>CS (SSI output)</b> Mating connector with 1 meter, 26 AWG cable	<b>Cable assembly, crimp style JST PHR-6 6-pin connector with 1 meter cable</b>	403608									
<b>H2 Protective Housing Accessory</b> <i>(Drawing dimensions are for reference only)</i>												
<b>Housing accessory and dimension references</b>	<b>Function</b>	<b>Description</b>	<b>Part number</b>									
  <table border="1" data-bbox="397 1722 706 1795"> <thead> <tr> <th>Part no.</th> <th>Material</th> <th>'D'</th> </tr> </thead> <tbody> <tr> <td>402809-1</td> <td>EPDM 20 ± 5 Shore</td> <td>3</td> </tr> <tr> <td>402809-2</td> <td>PTFE 50 ± 5 Shore</td> <td>1</td> </tr> </tbody> </table>	Part no.	Material	'D'	402809-1	EPDM 20 ± 5 Shore	3	402809-2	PTFE 50 ± 5 Shore	1	<b>CS/CM with H2-style housing</b> Use with the IP 67 H2 housing option	<b>Gasket (CPDM)</b>	402809-1
Part no.	Material	'D'										
402809-1	EPDM 20 ± 5 Shore	3										
402809-2	PTFE 50 ± 5 Shore	1										
	<b>CS/CM with H2-style housing</b> Use with the IP 67 H2 housing option	<b>Gasket (PTFE)</b>	402809-2									



## Models CS/CM Sensor Mounting and Installation

### C-SERIES CORE SENSOR MOUNTING

The C-Series Core Sensor features two mounting holes with sealed paths (see Figure 6). When mounting the sensor using the two holes, both sealed paths contain a breakaway plastic layer that can be gently tapped with a mounting screw and screwdriver end (or similar tool) or drilled. An O-ring groove is provided for embedded sealing (see Figure 6). Refer to 'Installation guidelines, Understanding the influence of magnets and magnetic fields', document number 551056, for magnet installation recommendations inside metallic structures.

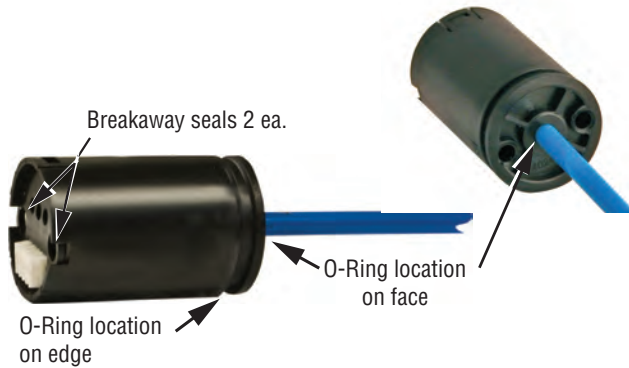

**Figure 6.** C-Series core sensor O-ring locations (for embedded applications)



**Figure 7.** C-Series core sensor mounting hole locations with M3 screws 37 mm (min.).

## Connections and wiring Models CS/CM

Connection is made using a 3-wire or 6-wire, 1 meter pigtail cable and 24 AWG wire respectively. Refer to tables 1 and 2 below for pinout, wire colors and functions. A mating connector and cable assembly (part no.: 253396 (4-pin) or 403608 (6-pin, SSI), or insulation displacement mating connector, (part no.:370500 or 370536) shown in Figures 8 and 9, are available as options.

### CS/CM Core Sensor 4-wire Connection Designations

Pin No.	Wire Color	Function
1	White	Common
2	Green	Voltage output
3	Brown	Supply Voltage (+)
4	N/A	N/A

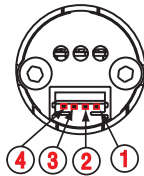

**Table 1.** 3-wire designations



**Figure 8.** C-Series core sensor 3-wire type connection

### CS/CM SSI 6-wire Connection Designations

Pin No.	Wire Color	Function
1	White	Ground
2	Green	Clk -
3	Brown	+12 Vdc
4	Yellow	Clk+
5	Gray	Data -
6	Pink	Data +

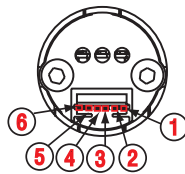

**Table 2.** 6-wire designations



**Figure 9.** C-Series core sensor SSI 6-wire type connection

**C-Series Core Sensor, Models CS/CM**  
**Mounting and Installation, Wiring and Connections**

**Connections and wiring Models CS/CM with M12 cable assemblies**

Connection is made using a 3-wire or 6-wire, 1 meter pigtail cable with 24 AWG wire. Refer to tables 3 and 4 for pinout, wire colors and functions. Approved M12 cable sets must be used *examples* shown in 'Figures 10 and 11'.

**Model CS/CM 5-pin M12 x 1 wiring diagram**

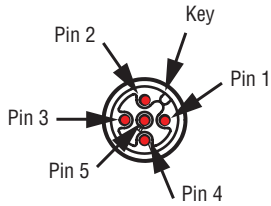

Pin No.	Wire Color	Function
1	Brown	Supply
2	Green	Voltage out
3	White	Ground
4	Yellow	N/C
5	N/C	N/C

**Table 3.** Analog output cable connection designations

**Model CS/CM 8-pin M12 x 1 wiring diagram**

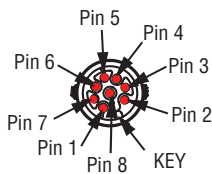

Pin No.	Wire Color	Function
1	Yellow	Clk +
2	Green	Clk -
3	Pink	Data +
4	Gray	Data -
5	N/C	N/C
6	N/C	N/C
7	Brown	Supply
8	White	Ground

**Table 4.** SSI output cable connection designations

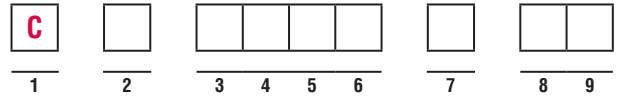

**Figure 10.** C-Series CS/CM analog 5-pin M12 type cable connection



**Figure 11.** C-Series CS/CM SSI sensor 8-pin M12 type cable connection

## C-Series Core Sensor, Models CS/CM Ordering Information



- |  |   |   |   |       |
|--|---|---|---|-------|
| <b>SENSOR MODEL</b>  |   | = | <span style="border: 1px solid black; padding: 2px 5px;">C</span>   | 1     |
| <b>C</b>   | = C-Series Core Sensor <i>(Order one magnet or magnet float per sensor separately. Refer to Accessory options)</i>  |   |   |       |
| <b>STANDARD OR MOBILE SUPPLY</b>                                     |   | = | <span style="border: 1px solid black; padding: 2px 5px;"> </span>   | 2     |
| <b>S</b>   | = 5 Vdc standard input  |   |   |       |
| <b>M</b>   | = 5 or 12 Vdc supply and enhanced EMI protection  |   |   |       |
| <b>STROKE LENGTHS</b>  |   | = | <span style="border: 1px solid black; padding: 2px 5px;"> </span> <span style="border: 1px solid black; padding: 2px 5px;"> </span> <span style="border: 1px solid black; padding: 2px 5px;"> </span> <span style="border: 1px solid black; padding: 2px 5px;"> </span> | 3 - 6 |
| <b>Enter four digit code (3 - 6) with no decimals as shown below</b> |   |   |   |       |
| <b>0072</b>  | = 72.3 mm (2.85 in.)  |   |   |       |
| <b>0109</b>  | = 109.5 mm (4.31 in.)   |   |   |       |
| <b>0128</b>  | = 128.3 mm (5.05 in.)   |   |   |       |
| <b>0148</b>  | = 148.0 mm (5.83 in.)   |   |   |       |
| <b>0162</b>  | = 162.3 mm (6.39 in.)   |   |   |       |
| <b>0186</b>  | = 186.3 mm (7.33 in.)   |   |   |       |
| <b>0194</b>  | = 194.3 mm (7.64 in.)   |   |   |       |
| <b>0217</b>  | = 217.3 mm (8.55 in.)   |   |   |       |
| <b>0250</b>  | = 250.1 mm (9.85 in.)   |   |   |       |
| <b>OUTPUT</b>  |   | = | <span style="border: 1px solid black; padding: 2px 5px;"> </span>   | 7     |
| <b>V</b>   | = Analog voltage, 0.1 to 4.9 Vdc  |   |   |       |
| <b>W</b>   | = Analog voltage, 0.5 Vdc to 4.5 Vdc  |   |   |       |
| <b>S</b>   | = SSI Binary code (Model CM only)   |   |   |       |
| <b>T</b>   | = SSI Gray code (Model CM only)   |   |   |       |
| <b>HOUSING OPTIONS</b>   |   | = | <span style="border: 1px solid black; padding: 2px 5px;"> </span> <span style="border: 1px solid black; padding: 2px 5px;"> </span>   | 8 - 9 |
| <b>P1</b>  | = Standard round plastic housing, includes JST PHR mating connector and requires an analog 1 meter cable, part no. 253396 or SSI 1 meter cable part no. 403608. |   |   |       |
| <b>H2</b>  | = Stamped IP67 stainless-steel housing with two hole flange   |   |   |       |
| <b>M1</b>  | = IP67 / 350 bar stainless steel Hex housing, 8 mm tube includes M12x1 connector  |   |   |       |



---

**Document Part Number: 551020, Revision L 02/12, 03/12**

MTS and Temposonics are registered trademarks of MTS Systems Corporation.  
All other trademarks are the property of their respective owners.

Printed in USA. Copyright © 2012 MTS Systems Corporation. All Rights Reserved in all media.



**MTS Systems Corporation  
Sensors Division**

3001 Sheldon Drive  
Cary, North Carolina  
27513, USA  
Tel.: +1-800-633-7609  
Fax: +1-919-677-2343  
+1-800-498-4442  
e-mail: [sensorsinfo@mts.com](mailto:sensorsinfo@mts.com)  
<http://www.mtssensors.com>

**MTS Sensor Technologie  
GmbH & Co. KG**

Auf dem Schüffel 9  
D - 58513 Lüdenscheid, Germany  
Tel.: +49-2351-9587-0  
Fax: +49-2351-56491  
e-mail: [info@mtssensor.de](mailto:info@mtssensor.de)  
<http://www.mtssensor.de>

**MTS Sensors Technology  
Corporation**

737 Aihara-cho, Machida-shi  
Tokyo 194-0211, Japan  
Tel.: +81-42-775-3838  
Fax: +81-42-775-5516  
e-mail: [info@mtssensor.co.jp](mailto:info@mtssensor.co.jp)  
<http://www.mtssensor.co.jp>